

Medium Voltage Surge Arrester - 1000V or Greater

Medium Voltage Surge Arrester



Interior Status Panel



Back with Mounting



The Medium Voltage SPD is an industrial-grade surge protection system engineered to safeguard critical medium voltage equipment from damaging transient overvoltages. Originally designed for demanding applications in resource extraction and industrial facilities, it delivers robust protection for systems operating from 1000V through 4160V.

Core Protection Technology

The system employs parallel-connected surge protection optimized for medium voltage applications:

- **Large and Robust UL Recognized Metal Oxide Varistors (MOVs)** – High-energy varistors engineered to handle the transient currents of medium voltage systems, providing superior surge current capacity and extended service life.
- **Thermally Protected MOVs (TPMOVs)** – Integrated thermal disconnect technology that permanently isolates failed varistor elements, preventing thermal runaway and ensuring continued protection even after component degradation.
- **Parallel Connected with Prewired 10kV Shielded Cable** – Factory-terminated #10 AWG shielded conductors rated for 10kV service, pre-installed with 1.5" conduit hub for streamlined field installation.

Operational Monitoring & Diagnostics

The system incorporates monitoring features that enable proactive maintenance and fault diagnosis:

- **Isolated Test Points** – Safely accessible test points housed within the enclosure on a dedicated panel behind the door, allowing technicians to verify unit performance without exposure to system level voltages.
- **Per-Phase Manual Status Testing** – Individual phase testing capability enables precise diagnostics and confirmation of protection integrity for each line conductor independently.

Industrial Construction & Reliability

Built to withstand harsh environments where contamination and environmental exposure can threaten equipment reliability:

- **Potted Internal Components** – Critical surge protection elements are fully encapsulated in protective potting compound, preventing moisture ingress, dust contamination, and chemical exposure that could compromise performance.
- **NEMA 4X Rated Enclosure** – Corrosion-resistant construction provides weatherproof and dusttight protection, suitable for both indoor and outdoor installations in industrial atmospheres.

Flexible Voltage Configurations

The Medium Voltage SPD is available in multiple voltage ratings to precisely match your system requirements: 1000V, 1500V, 2500V, 3600V, and 4160V. Each configuration is optimized for its specific voltage class, ensuring proper coordination with upstream and downstream equipment while maintaining adequate protection margins.

Manufacturer Recommends Best Practice of Installing Behind Fusing or a Breaker

Unit is not operator serviceable - Do NOT open unit behind Status Panel
Opening unit panel will expose you to high voltages and may result in serious injury or death - standard Shock Hazard labels will be on the unit.

Rev 26.01.16-1.1

General Technical Specifications

Connection Type:	Parallel, Pre-wired Wire Lead
Wire Lead Specifications:	8 Ft of 10kV Shielded #10 AWG 1.50" Internally Threaded Conduit Hub
Voltage, Phase Configuration:	1000V, Three Phase Delta, (3W+G) 1500V, Three Phase Delta, (3W+G) 2500V, Three Phase Delta, (3W+G) 3600V, Three Phase Delta (3W+G) 4160V, Three Phase Delta (3W+G)
Maximum Continuous Operating Voltage:	1000V, 1380 VAC (125%); 1500V, 2000 VAC (125%); 2500V, 3400 VAC (125%); 3600V, 4800 VAC (125%); 4160V, 5500 VAC (125%);
Surge Capacity:	50kA/Mode, 100kA/Phase
Short Circuit Current Rating (SCCR):	MOV Components Rated to SCCR 200kAIC
Protection Modes:	All Available Modes: L-L, L-G
Operating Frequency Range :	47 - 63 Hz
Location Type:	Suitable for High Energy Applications Including Category A, B, & C High Energy
Nominal Discharge Current (In):	20 kA
Status Indication:	Isolated test points for each phase
Enclosure:	NEMA 4, 4X, 12, & 13 Rated Polycarbonate Detachable Flange Mounting Bracket Kit Included
Enclosure Size: Mounting:	15.25" x 14.00" x 7.22" (7.72" w/ Feet) (H x W x D) 15.25" x 9.50"
Standards Tested Consistent With:	UL-508A Listed ANSI/IEEE 62.11 IEEE C62.41.2
Response Time:	<0.5 nanoseconds
Operating Temperature:	-40°C to +75°C
Operating Humidity:	0% to 95% non-condensing
Warranty:	5 Years

Medium Voltage Surge Arrester Dimensional Drawing

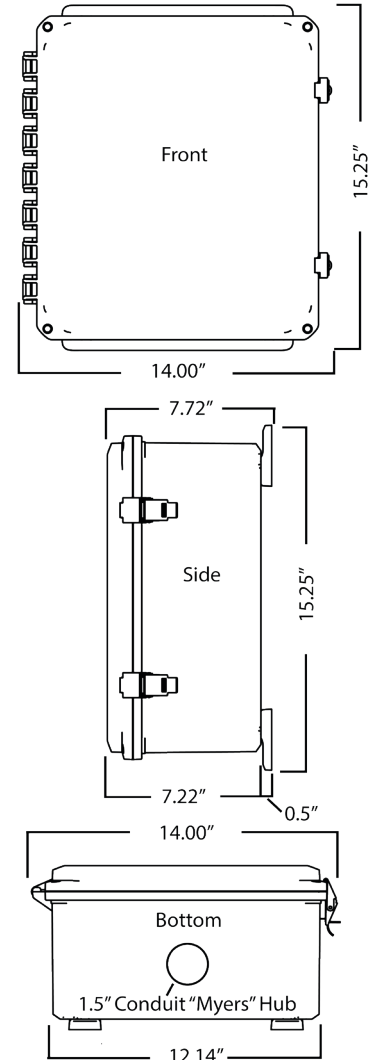

T65



T65 - 650 MVSPD

Voltage Code

100 = 1000V
150 = 1500V
250 = 2500V
360 = 3600V
416 = 4160V

Phase

D = Three Phase
Delta

Protected Modes

A = All Connected Modes

Connection

W = Wire Lead

Status

S = Manual Status

650 Family Ordering Information: Example Model Number: T65360DAWS

Rev 26.01.16-1.1