

Medium Voltage Digital Monitoring Panel



The Power Quality Monitoring Panel is a low- or medium-voltage measurement device that revolutionizes safety for technicians and personnel. The Monitoring Panel provides a digital display that allows for the measurements of voltage, current, power, and frequency without the need to use a meter and test leads.

This device requires separate connections for voltage and current; both are connected in parallel. This device is available in Medium-Voltage configurations, up to 5000V, or Low Voltage configurations up to 600V.

The Monitoring Panel takes the line voltage and reduces it 100:1 to a safer level where they can be monitored without the need for excessive personal protective equipment. There is one conductor per phase for the voltage connection. Connections can be made at the source, the connected device, or on the line anywhere in between. The metrics for the voltage can be read on the digital display, where it will show the real-time actual values. Additionally, they can be read with a meter by using test leads and the available voltage taps on the Monitoring Panel at their reduced values; you must use the reduction ratios to calculate the full line reading.

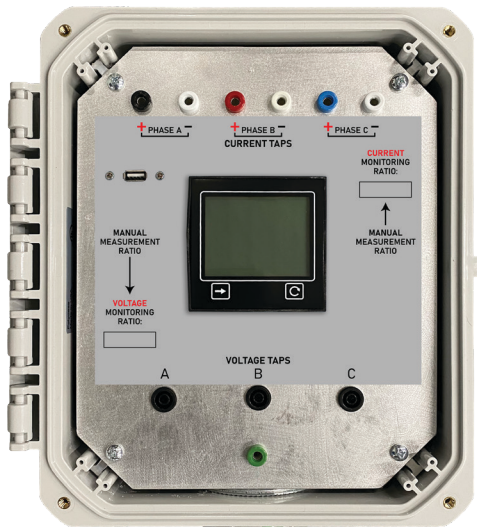

This system also measures current with the use of current transformers. The factory default is 200:5 current transformers for the medium voltage unit, but the system is USB programmable for user-defined transformers. One transformer is required per phase. If using solid-core transformers, in order to feed it through the center of the current transformer, it will require the conductor to be disconnected from either the source or the connected device. The metrics for current can be read on the digital display, where it will show the real-time actual values. Just like with voltage, there are taps provided to manually read current with a meter and test leads, and it will require the use of the current ratio to calculate the actual value.

The Medium Voltage Monitoring Panel will remain on, active, and monitoring, even if the monitored equipment is disconnected from the power. It requires a separate low-voltage power connection for the digital display to function; 25 ft leads with a 0.5" conduit hub are provided. The Low Voltage Monitoring Panel is self-powered from the connected voltage, and the display will turn off if the power is disconnected.

All standard Medium Voltage Power Quality Monitors will ship with 3 Solid-Core 200:5 Current Transformers—for a custom configuration, please consult your sales representative.

Note: Current Transformers are polarity sensitive, H1(Line side) must face the source, or the polarity will be reversed.



Medium Voltage Digital Model

Rev 25.10.29-1.1



Medium Voltage Digital Monitoring Panel

Voltage Measuring	
• Voltage Input Range:	0 - 5000V
• Operating Frequency:	0 - 400Hz
• Input Impedance:	500k Ohm
• Input Load:	2 Watts
• Manual Voltage Test Point Ratio:	100:1
Current Measuring	
• Manual Current Test Point Ratio:	200:5
• Standard CT Current Ratio:	200:5
• Standard Solid CT Inner Diameter:	1.13"
• Standard CT Dimensions:	2.68" x 2.5" x 2.00"
• Standard CT Mounting Dimensions:	1.75" x 1.75"
General Technical Specifications	
• Connection Type:	8 ft #10 AWG 10kV w/ Shield Wire Leads For Voltage 10 ft Twisted #14 for Current
• Digital Display Measurements:	Voltage, Current, Power, kWh, Frequency
• Remote Programming:	USB-A Port
• Remote Monitoring:	Modbus Through Externally Accessible RJ45 Connection
• Power Requirements:	Externally Powered Display 600VAC - 277VAC; 25ft Remote Power Leads Included 0.5" Conduit Hub
• Accuracy:	+/- 1% @ 55°C
• Main Conduit Hub	2" Diameter
• Communications Conduit Hub	1" Diameter
• Enclosure:	NEMA 4X Polycarbonate
• Enclosure Dimensions (body):	10" x 8" x 6" (H x W x D)
• Total Footprint:	12.50" x 10.25" x 7.72"
• Mounting Dimensions (flange):	11.25" x 5.50"
• Operating Temperature:	-40°C to +85°C
• Operating Humidity:	0% to 95% non-condensing
• Country of Manufacture:	United States of America
• Warranty:	3 Years

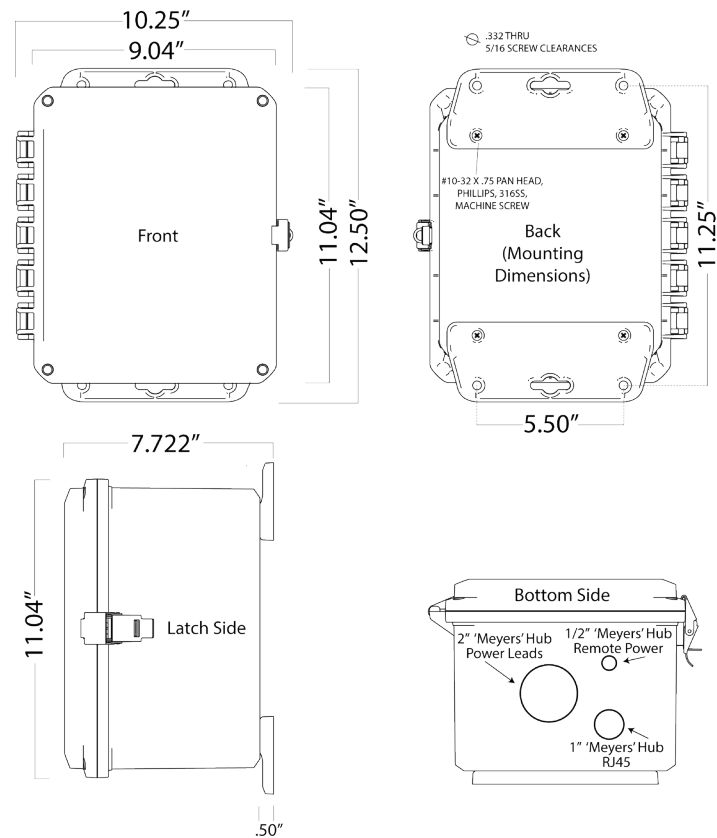
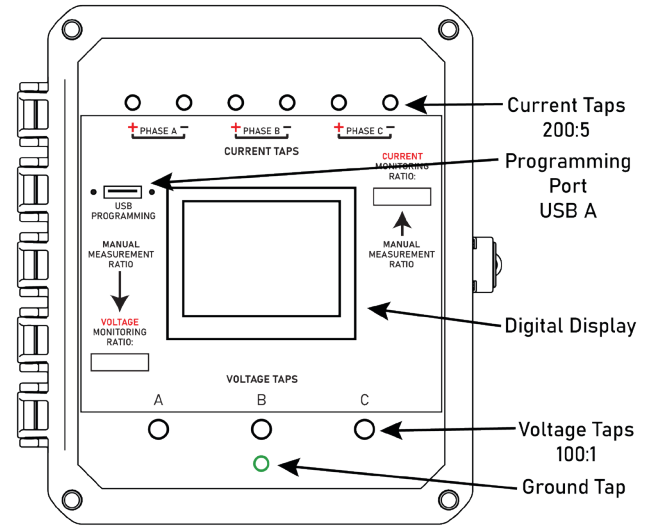

PQGMP



Product Family
PQGMP = PQ Global Monitoring Panel

Voltage
MV = Medium Voltage
LV = Low Voltage

Monitor
D = Digital
M = Manual

Example Product Number:
PQGMP - MVD

Rev 25.10.29-1.1



Current Transformer Ordering Information - Standard Offering 200:5 CT

The technical data on this sheet is for our standard 200:5 solid-core current transformers and does not apply to other configurations. The product is not limited to this configuration and can be customer specified; just reflect the necessary "Current Ratio" for your current ratio in the product number ordering information below. If no number is appended to the base Monitoring Panel order, CTs will not be included on low voltage models. If no number is appended to the Medium Voltage model base unit it will come with 3 standard 200:5 solid core CTs.

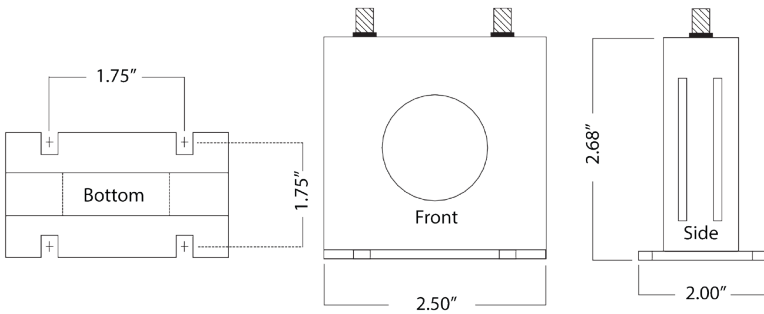

General Technical Specifications - 200:5 CT	
CT Quantity Required For Ziton	3
Current Ratio	200:5
Window Diameter	1.13"
Frequency Range	50Hz - 400Hz
Insulation Voltage	3500 VAC/1min
Accuracy @ 60Hz	± 1%
Thermal Drift	100 PPM/ °C
Installation Category	CAT II
Studs	#8-32
Torque Spec on Studs	10 in/lb.
Pollution Degree	2
Operating Temperature	-20° C to +75° C
Dimensions	2.68" x 2.50 x 2.00"
Mounting Dimensions	1.75" x 1.75"
Standards	UL, CUL, CE, RoHs recognized
Warranty	3 Years

NOTE: The current transformers are polarity-sensitive! They must be installed with H1 (line side), the lettering on the CTs, facing the source. Improper wiring will result in the reversed polarity of the current reading.

If the current transformer is not connected to the Monitoring Panel, short the X1 terminal (positive) to the unlabeled terminal X2 (common), since high voltages can be induced in the transformer secondary windings.

Connect the Positive from the Monitoring Panel, the colored (non-white) wire that corresponds to the respective phase, to the X1 (positive) terminal on the CT. Connect the corresponding common white wire to the unlabeled terminal on the CT (X2 - Common).

Remove the short between terminals after wiring.

CT Ordering Information

Standard Qty 3 x CT 200:5 Amp

Add - **CTxxxx** to the end of product #

Example: Standard 200:5

PQGMP - MVD - **CT02005S**



Product ID

CT = Current Transformer

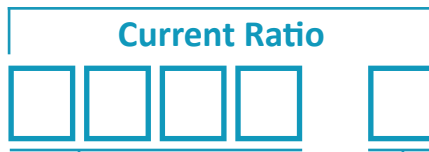

Primary Input

0200 = 200A

XXXX = xxxxA

Secondary Output

5 = 5A



Core Design

S = Solid

P = Split

